

## TechTip: AS-i piercing technology

During the configuration of an AS-i bus a continuous cable is used to connect the individual bus nodes. This cable is connected to the individual nodes by means of the so-called penetration technology. In this technology the cable is no longer separated into individual cables, in contrast to the clamping technology.



So-called connection splicers are used in Eplan to represent the behavior described above.

Each AS-i node is represented by a **PLC box** in which the **connection splicer** with a **connection definition point** (CDP) and the actual **bus port** are located:

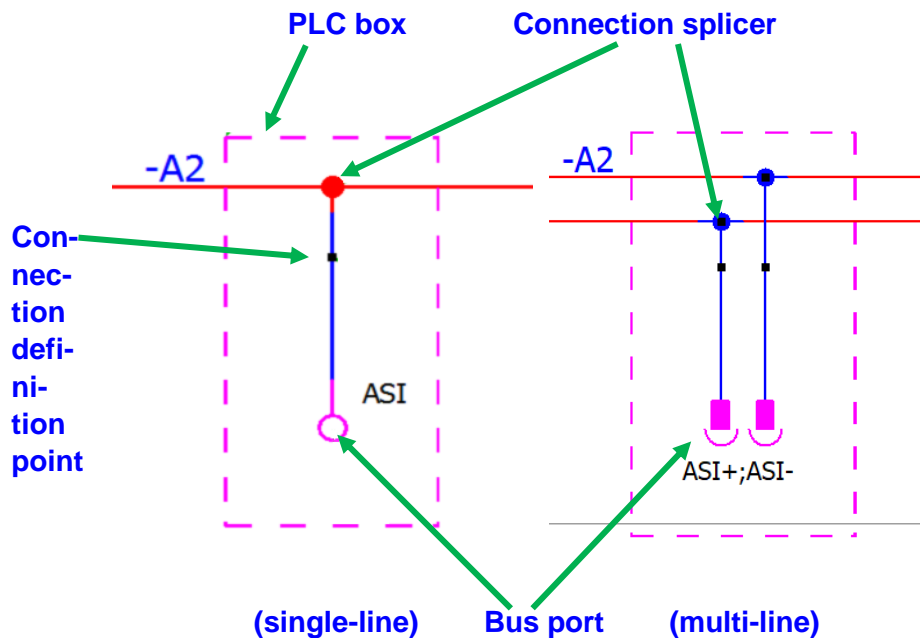

Use a symbol with fitting connection number for the multi-line representation (see chapter [Displaying Bus Ports in Multi-line](#) in Eplan Help).

The following settings are to be carried out at the individual elements:

### Bus port

- The **Displayed DT** entry remains empty. The bus port adopts the DT of the PLC box.
- **Bus system** = ASI
- Further settings are effected depending on the requirements.

### Connection splicer

- The **Displayed DT** entry remains empty. The connection splicer adopts the DT of the PLC box.
- Deactivate the **Main function** check box.
- Use the **Continuous connection between the connection points** property to determine the signal transfer between the desired connection points.
- Further settings are effected depending on the requirements.

### Connection definition point

- **Function definition** = Direct connection

### PLC box

- No special settings. Settings are carried out depending on the requirements.

The following procedure is recommended when using the connection splicers:

1. At the AS-i device no template is created for the connection splicer on the **Function templates** tab in the parts management.
2. A macro is created for the AS-i device. The connection splicer is configured here. This macro is stored in the parts management on the **Technical data** tab in the **Macro** property and is used for the configuration.

Connection of the connection splicers is effected through autoconnect lines. A cable definition line is configured correspondingly for the cable definition of the continuous cable.

At the interface of the cable definition line with the autoconnect line a connection definition point arises at which the list of the connection splicers passed through can be displayed:

1. In the property dialog of the connection definition points change to the **Display** tab.
2. Use the "New" button under **Source object** = "Connection" to select the property **Connection splicers passed through** (ID: 31136).

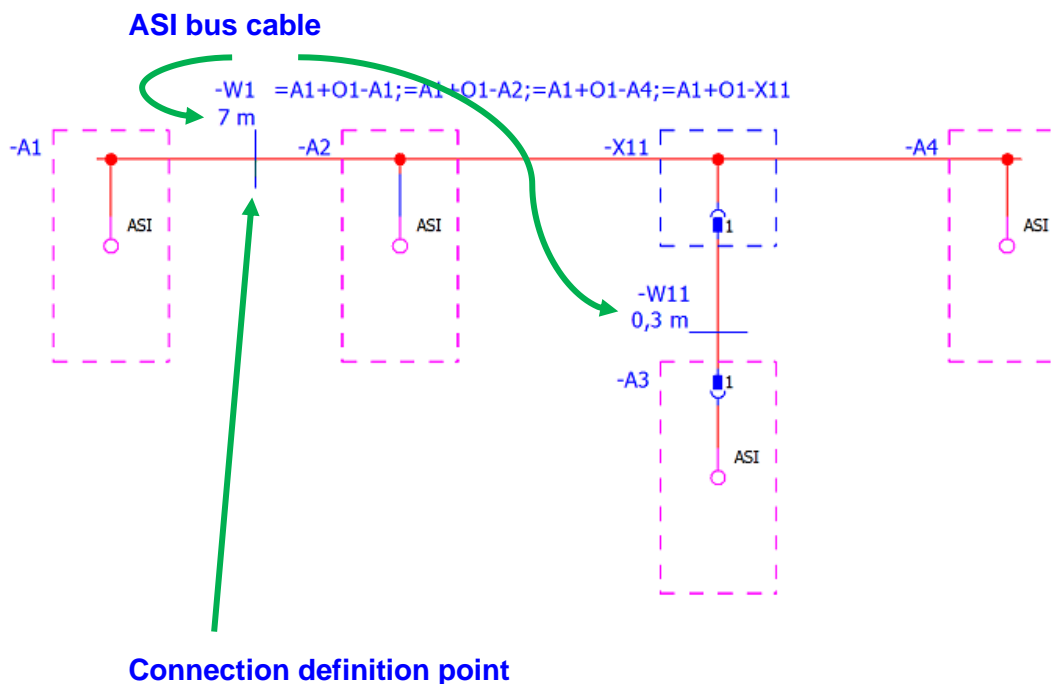

3. The display of the list of the connection splicers passed through can also be carried out line-oriented (under each other) by using an alignment box.

Connection splicers passed through can also be output in the "Cable diagram" report. The **Cable: Connection splicers passed through** (ID 35111) property is available to this purpose.