

# TechTip: Preparation for the master data for the PLC data exchange

## Contents

1.	General.....	2
2.	Preparation of the parts data.....	2
2.1.	Overview of the most important part properties.....	3
2.2.	Configurable PLC connection points (multi-function connection points) .....	4
2.3.	Deactivated I/O connection point.....	5
2.4.	PLC I/O connection point or bus port.....	5
2.5.	Tab Properties.....	6
2.6.	Tab Function templates.....	9
2.6.1.	Specifying function definitions .....	9
2.6.2.	Properties in the function templates .....	19
2.7.	PLC devices with subdevices .....	20
3.	Macro creation.....	21
3.1.	Standardized macros.....	21
3.2.	Data in the macro.....	22
3.3.	Graphical view.....	23

## 1. General

Already today the Eplan Data Portal supplies a multitude of manufacturer information and part macros. Nevertheless, It is possible that a used PLC card is not available there.

This TechTip helps you to create parts and macros for your PLC devices in such a manner that they can be reused easily.

For the fundamental description of a property please refer to the Eplan help of Version 2.9:

- [Terminals, Cables, Plugs, and PLC Information > PLC > Basics](#)
- [Eplan Properties: Overview](#)

You can find further notes and specifications on individual properties in the TechTip:

- [TechTip-Overview-of-the-PLC-properties](#)

### Information for reading

Structure of the individual tables:

Property	<ID>
Input format	
<i>Special features</i>	

## 2. Preparation of the parts data

In the parts management you already specify in advance the properties of the PLC device or a bus-compatible device that do not change in your project (*fixed and device-dependent data*). These data are transferred from here to your project at a part or device selection.

The following tabs, amongst others, are available to you to enter PLC-relevant data:

- Properties
- Function templates.

## 2.1. Overview of the most important part properties

In the parts management the appropriate properties have to be filled or the check boxes activated:

ID	Property
22105	PLC type designation
22038	Object description
22037	Device description: File name
22283	Device description: Index in file
22269	PLC station: Type
22019	Bus coupler / head station
22020	CPU
22052	Power supply
22053	Bus distribution device

- Each part requires a unique [Device identification](#) (**PLC type designation** or in the combination of **Device description: File name** and **Device description: Index in file**). *The check runs 501025 and 501034 support you with the search for empty or non-unique device identifications. For further information please refer to the Eplan help in the section "[Check part master data](#)".*
- For each CPU and each head station (first PLC card on the rack with network connection) the property **PLC station: Type** must be filled. *The manufacturer name is sufficient for most manufacturers. There are fixed designations for Siemens devices. These are specified in the TechTip "**TechTip-Overview-of-the-PLC-properties**", chapter "Settings at PLC devices".*
- For devices with CPU the **CPU** check box must be activated.
- For devices with bus ports the **Bus coupler / head station** check box has to be activated.

The following function templates are defined:

- Each PLC device has a "PLC box" function definition.
- Each PLC connection point has a function template.

3. For each I/O connection point the **Channel designation** has to be numerically filled. Due to the possible combination of connection points, we recommend entering the **Channel designation** for safety controllers not at the parts but in the macro.
4. A bus port (port / plug) only has **one** function definition since it is always configured as a plug and not through individual contacts.  
The following applies at the function definition of the bus port:

ID	Property	Value
20406	Plug designation	Is filled
20447	Bus interface: Name	Has to be filled for Ethernet-based bus systems
20308	Bus system	Is filled
21000	Connection point designation	Is empty
21007	Connection point description	Is empty
20384	PLC subdevice: Index	Specifies to which PLC subdevice the bus port belongs. If a device has no subdevices, therefore the value is "0".

## 2.2. Configurable PLC connection points (multi-function connection points)

In the field of PLC devices there are increasingly devices whose PLC connection points are configurable: PLC connection points can be either inputs or outputs.

In order to minimize the number of parts data and required macros in this case it is possible to define PLC connection points as a *PLC connection point, multi-function*.

The behavior of this connection point is then determined for these PLC connection points with the **Type of signal** property set in the [Connection point logic](#).

### Advantages:

- Reduction of the parts data and macros;  
only one part record without parts variants and one macro
- Correct overlapping of the function templates in the navigators

### 2.3. Deactivated I/O connection point

Multiple I/O connection points can be combined into one channel for modules with analog connections or [safety controllers](#).

In Eplan only one connection point from the category *PLC connection point, I/O, 1 connection point* may be active within one channel in Eplan. If a channel has more than one PLC I/O connection point, mark the other connection points of the channel with the property **Deactivated I/O connection point**. This way these connection points are not filled with data inaccurate for the PLC configuration program during the PLC data exchange.

To allow the post-addressing of these connection points in Eplan, enter the same value in the **Channel designation** field for each of the combined connection points.

### 2.4. PLC I/O connection point or bus port

In the area of PLC devices there are devices whose PLC connection points can be either an input or output or bus port (for example I/O link devices).

In this case use the possibility to create variants in the parts management:

- In Variant 1 the affected PLC connection points are defined as bus ports
- In Variant 2 the affected PLC connection points are defined as *PLC connection point, multi-function* (see above)

A common macro can be used for both variants since the suitable variants for the affected PLC connection points can be created in the macro.

#### Disadvantage:

- In Eplan it is not possible to select the correct part variant during the PLC data import since both part variants have an identical PLC type designation. In this case Eplan always uses the first found variant. You are pointed to these circumstances with the check run [004057](#). If necessary, correct the part at the affected modules after the import.

## 2.5. Tab Properties

### PLC data nodes

<b>PLC type designation</b>	<b>22105</b>
String	
<i>The value has to be filled in at all the PLC cards or bus-compatible devices if the "Device description: File name" is not filled.</i>	
<i>As a rule the original order number under observance of any blanks and separators is to be specified.</i>	

<b>Device description: File name</b>	<b>22037</b>
File name of the device description file with file name extension and without file path specification	
<i>The value has to be filled at all the PLC cards or bus-compatible devices if the "PLC type designation" is not filled.</i>	
<i>Is used together with Device description: Index in file.</i>	

<b>Device description: Index in file</b>	<b>22283</b>
Numerical reference to the device in the file specified by means of <i>Device description: File name</i>	
<i>Is used together with Device description: File name.</i>	

You will find detailed information on the use of **PLC type designation**, **Device description: File name** and **Device description: Index in file** in the Eplan Help in the section "[Data Exchange of PLC Configuration Files](#)" with the keyword "Device identification".

<b>Object description</b>	<b>22038</b>
Any string	
<i>Designation of the PLC box.</i>	

<b>Version</b>	<b>22104</b>
Any string	

<b>PLC station: Type</b>	<b>22269</b>
--------------------------	--------------

String, depending on the target system

*The value has to be filled in at each PLC box that represents a CPU or a head station or is a bus-compatible device.*

**Bus coupler / head station**

**22019**

Check box

*All PLC boxes or bus-compatible devices that represent a bus coupler or a head station have to be identified by activating the check box.*

**CPU**

**22020**

Check box

*All PLC boxes or bus-compatible devices that represent a CPU have to be identified by activating the check box.*

**Power supply**

**22052**

Check box

*All PLC boxes or bus-compatible devices that represent a power supply have to be identified by activating the check box.*

**Bus distribution device**

**22053**

Check box

*All PLC boxes or bus-compatible devices that represent a bus distribution device have to be identified by activating the check box.*

**PLC card is placed on head station**

**22290**

Check box

*Identifies a PLC card that is placed on a head station or is integrated into it and is not adjoined next to the head station.*

<b>Address range (SIEMENS STEP 7 Classic), Address range 2 (SIEMENS STEP 7 Classic)</b>	<b>22106, 22261</b>
Numerical value	
<p><i>Address range: Specification for inputs. Can also be used for outputs if the card only has outputs.</i></p> <p><i>Address range 2: Specification for outputs.</i></p> <p><i>Is only used at SIEMENS STEP 7 Classic and, depending on the PLC card, determines the number of input / output bits or bytes.</i></p>	

<b>PLC device: Data length (inputs), PLC device: Data length (outputs)</b>	<b>20571, 20573</b>
Numerical value	
<p><i>Number of bits up to the next free address on the next PLC card.</i></p>	

A PLC card can consist of multiple integrated modules (subdevices), that each have their own [Address ranges](#) and start addresses. Each subdevice is defined by corresponding properties. Up to twelve subdevices can be specified (in the text below x designates the number of the subdevice 1...12). See also chapter "[PLC devices with subdevices](#)".

Subdevices are exported if they have at least one start address or a [Device identification](#).

**Note:**

If a PLC card has no subdevices (meaning that it only consists of one module), definitions for these can be omitted. The value "0" is entered at the **PLC subdevice: Index** property at the associated PLC connection points.

You can obtain further information on the definition of subdevices from the manufacturer of the PLC device or in the TechTip "[TechTip-Configuring-PLC-devices-with-device-description-files](#)".

<b>PLC subdevice x: Name</b>	<b>22293 foll.</b>
Any string	

<b>PLC subdevice: Position (slot / module)</b>	<b>22305 foll.</b>
Numerical value	



<b>PLC subdevice x: Data length (inputs), PLC subdevice x: Data length (outputs)</b>	<b>20572 foll., 20574 foll.</b>
Numerical value	
<i>Number of bits up to the next free address on the next PLC card.</i>	

<b>PLC subdevice x: PLC type designation</b>	<b>22365, 22341 foll.</b>
Any string	
<i>This property has to be filled for subdevices if these are expected as independent devices in the PLC configuration program.</i>	
<i>As a rule the original order number under observance of any blanks and separators is to be specified. Every subdevice can only have <b>one</b> PLC type designation. A combination of several parts by entering several PLC type designations is not supported.</i>	

<b>PLC subdevice x: Device description: Index in file</b>	<b>22366, 22352 foll.</b>
Numeric reference to the device in the device description file that is entered at the PLC box (main device) in the property <i>Device description: File name</i> .	
<i>This property has to be filled for subdevices if these are expected as independent devices in the PLC configuration program and are identified via a device description file and the associated index.</i>	
<i>Notes: The device description file is specified at the PLC box (main device). The indexes of the device description files additionally have the specification of a context in the AML file. For a subdevice this context <b>must</b> always be specified during the configuration:</i>	
<ul style="list-style-type: none"> <li>• /D (Device)</li> <li>• /R (Rack)</li> <li>• /DAP (Device Access Point)</li> <li>• /M (Module)</li> </ul>	

## 2.6. Tab Function templates

### 2.6.1. Specifying function definitions

A function definition is assigned to each PLC connection point. However, this is not possible if the relevant module is not known. Therefore, it is necessary to obtain the data sheet of the module from the manufacturer. Reference to the hardware catalog or the corresponding device manual (in many cases available as a download from the manufacturer site) can help.

In the following example the procedure is shown as an example. An analog module of SIEMENS (6ES7331-7HF0x-0AB0: SM 331: AI 8 x 14 bits) is used.

Data sheet extract of manufacturer

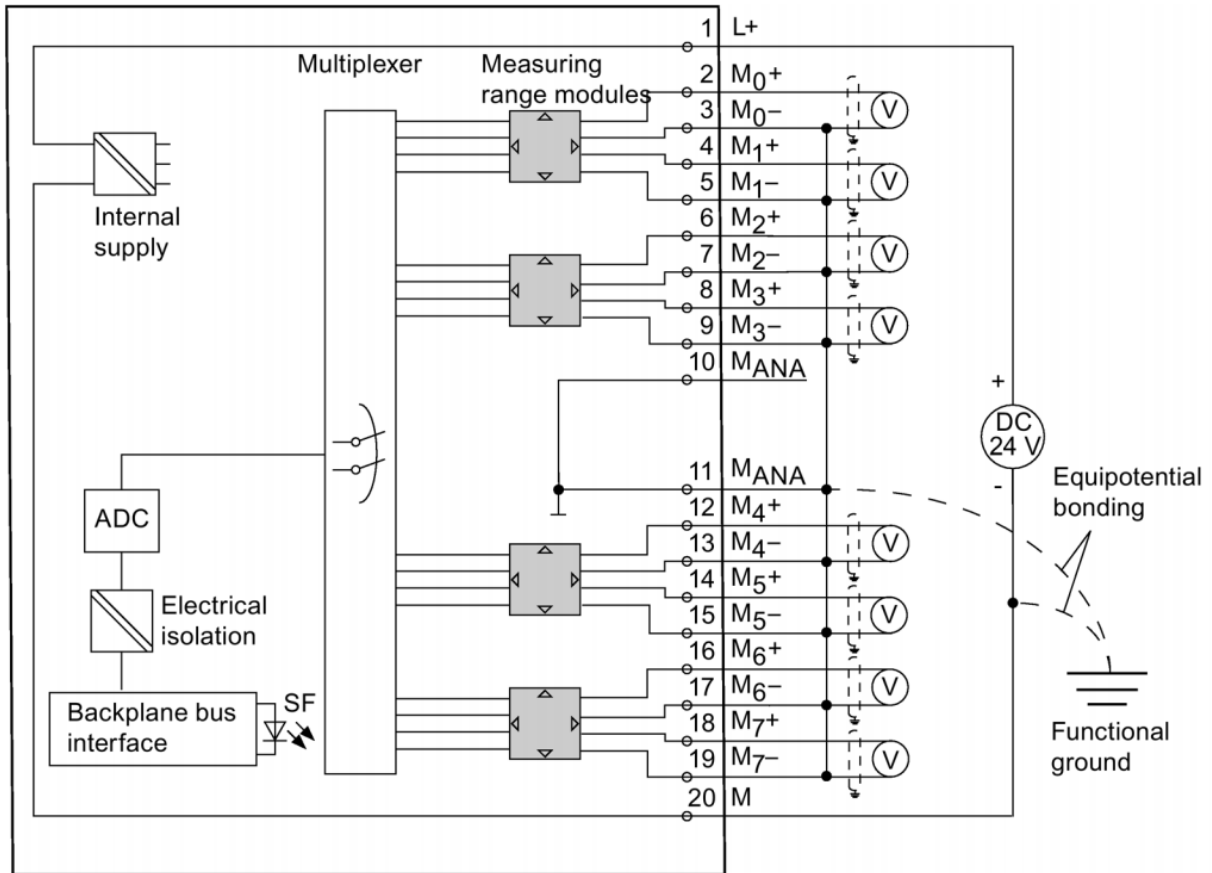

## Identifying channel-independent connection points

Channel-independent connection points are all connection points that cannot be assigned directly to one individual channel. These are

- Card power supplies
- Power supplies that are used for more than one channel.

Use the function definitions from the **Card power supply, 1 connection point** group for these connection points.

- Use the **Network- / Bus cable** function definitions from the group for bus ports

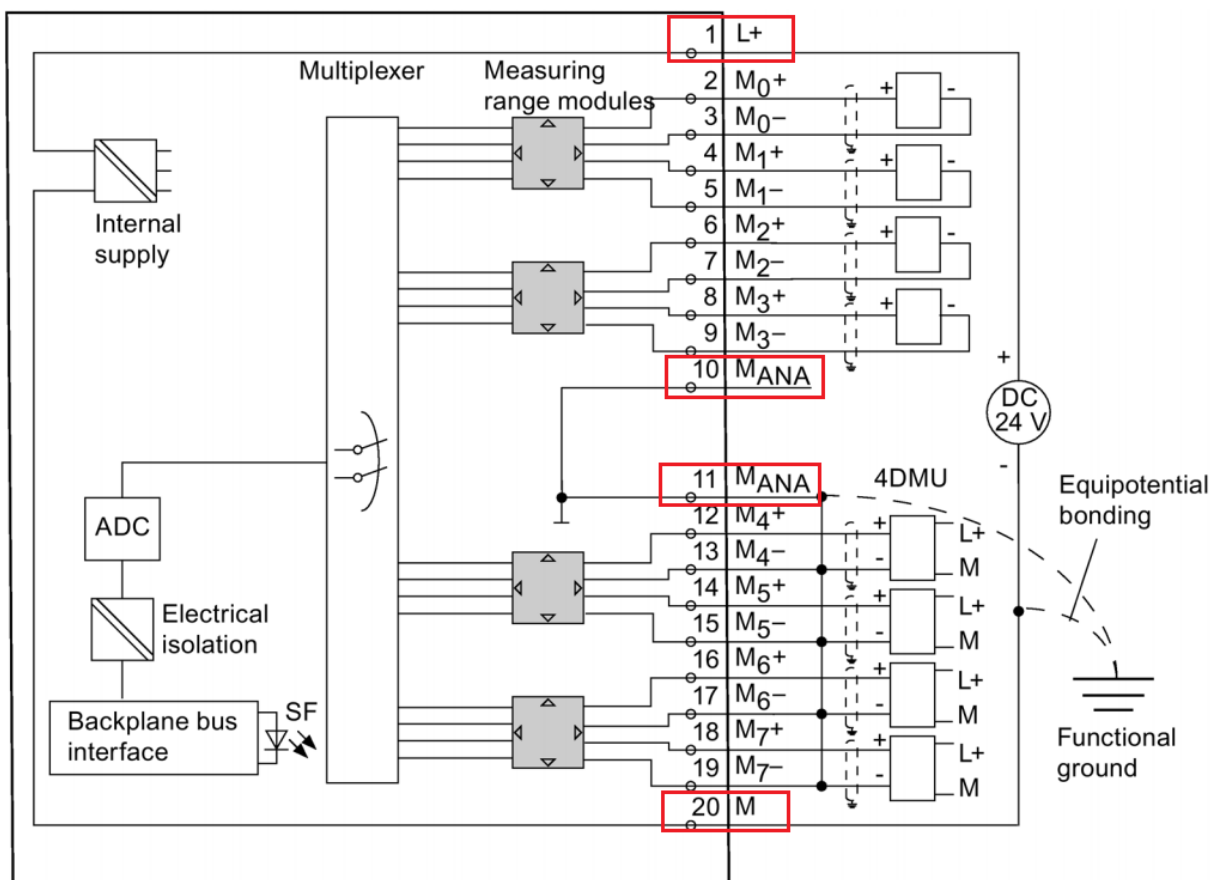

The function templates are selected according to the connection point description specified by the manufacturer:

- L+ → CS (+)
- L- → CS (-)
- M<sub>ANA</sub> → CS (M)
- M<sub>ANA</sub> → CS (SH)

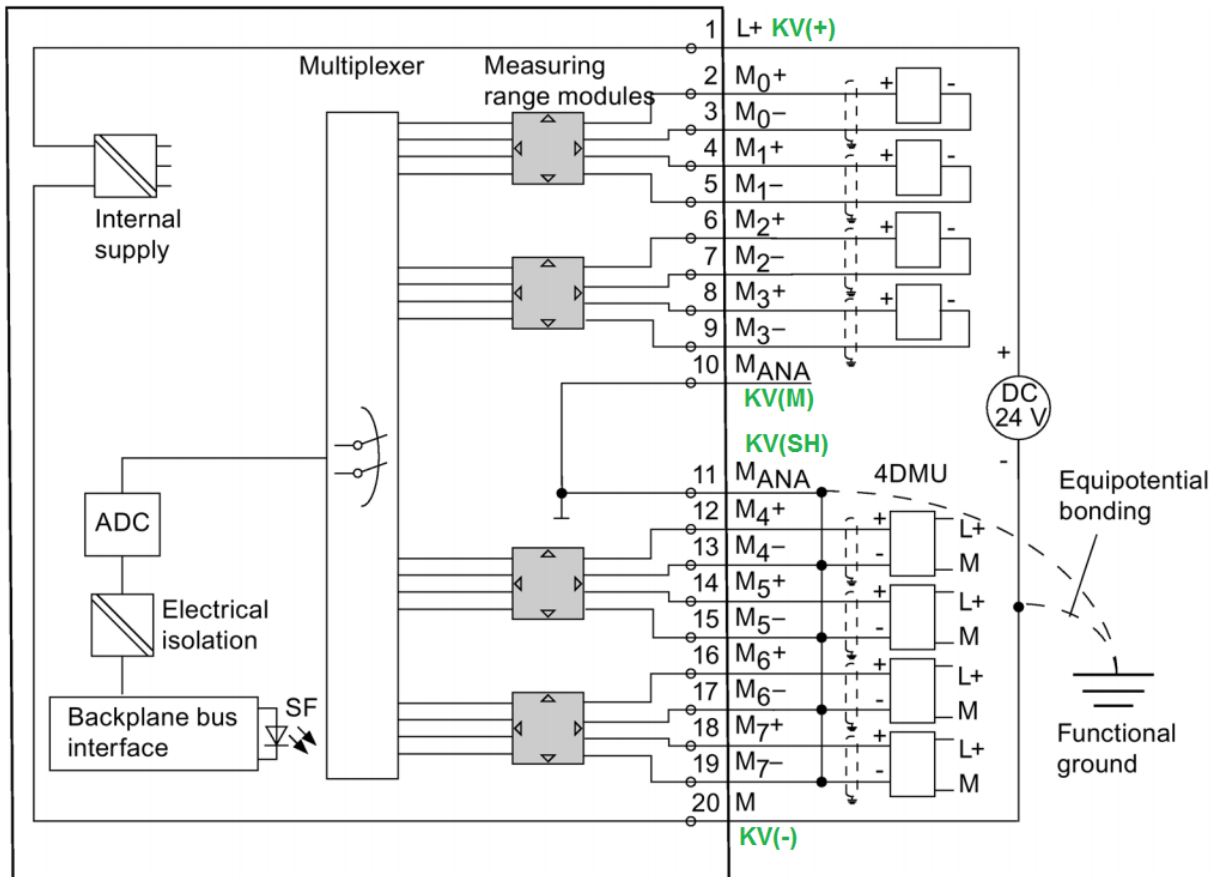

### Identifying channels

Now the channels are selected from the remaining connection points. In our example you can see eight identical channels:

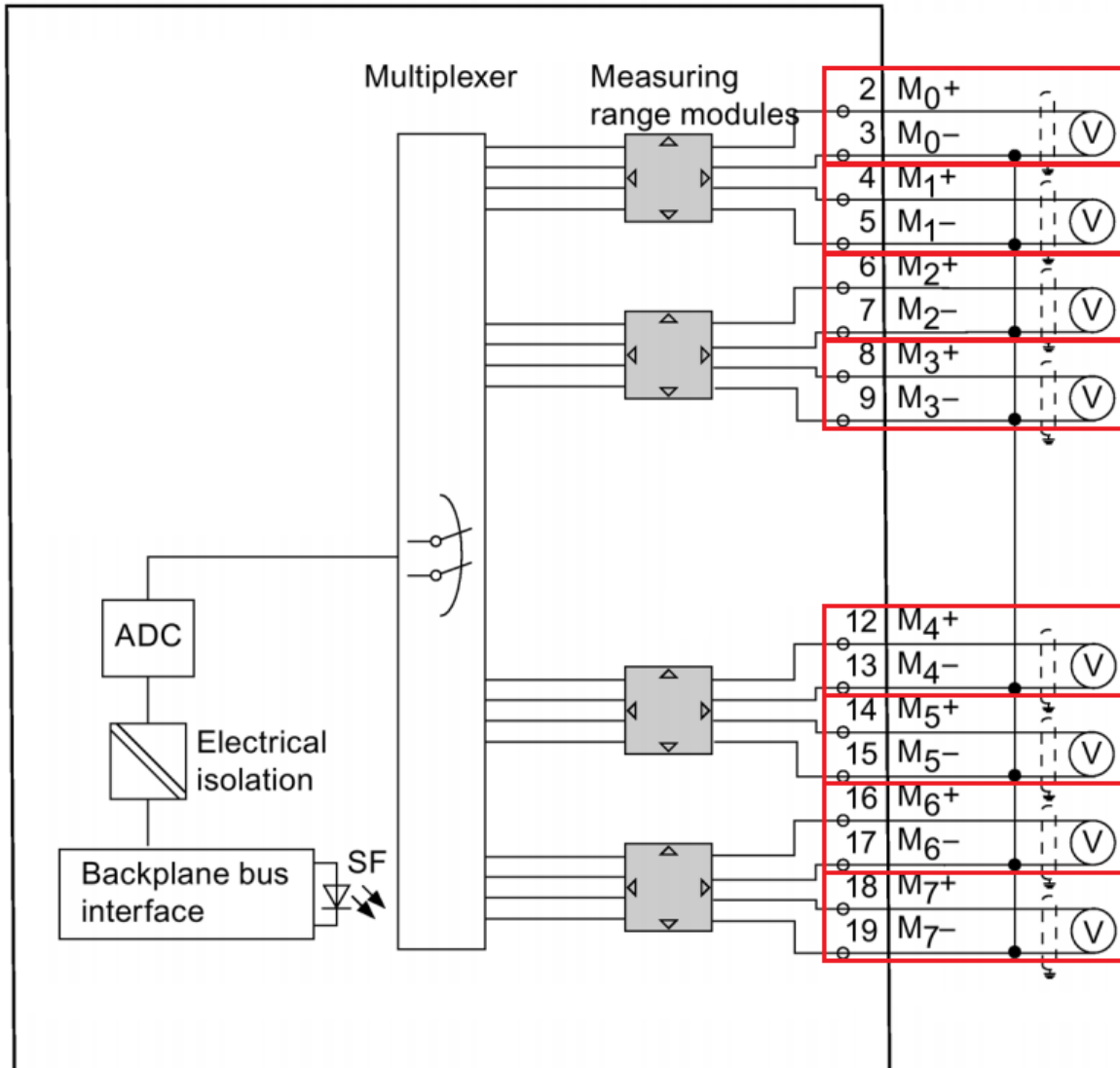

## Looking at a channel

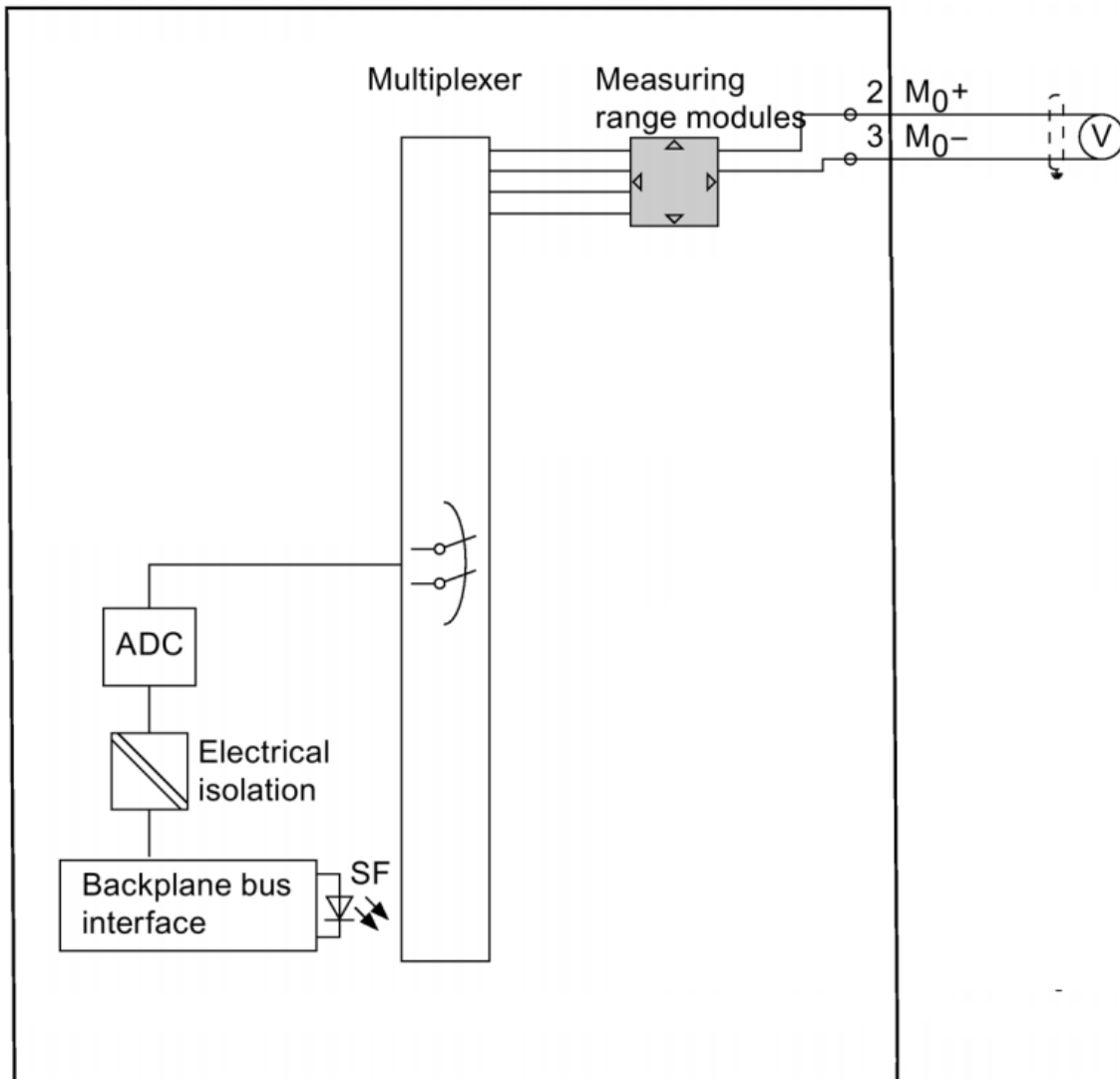

- Within a channel there can only be one active PLC connection point (input or output) among all connection points of a channel.
- All other connection points have to either have a function definition from the **Power supply, 1 connection point** range or must be deactivated.

A PLC connection point is activated or deactivated with the check box **Deactivated I/O connection point**. A deactivated PLC connection point acts like a power supply.

- Each function definition from the group of the power supplies must only be assigned once for a channel. Otherwise [Writing back the connection point designations](#) of the overview page on the schematic page is not possible without errors.
- For the function definition **PLC connection point, multifunction** the type of signal in the logic is used to determine which actual function is used (see section "[Configurable PLC connection points](#)" in the Eplan help).

- If none of the special function definitions matches at a card, you use the function definition **PLC connection point, general**.

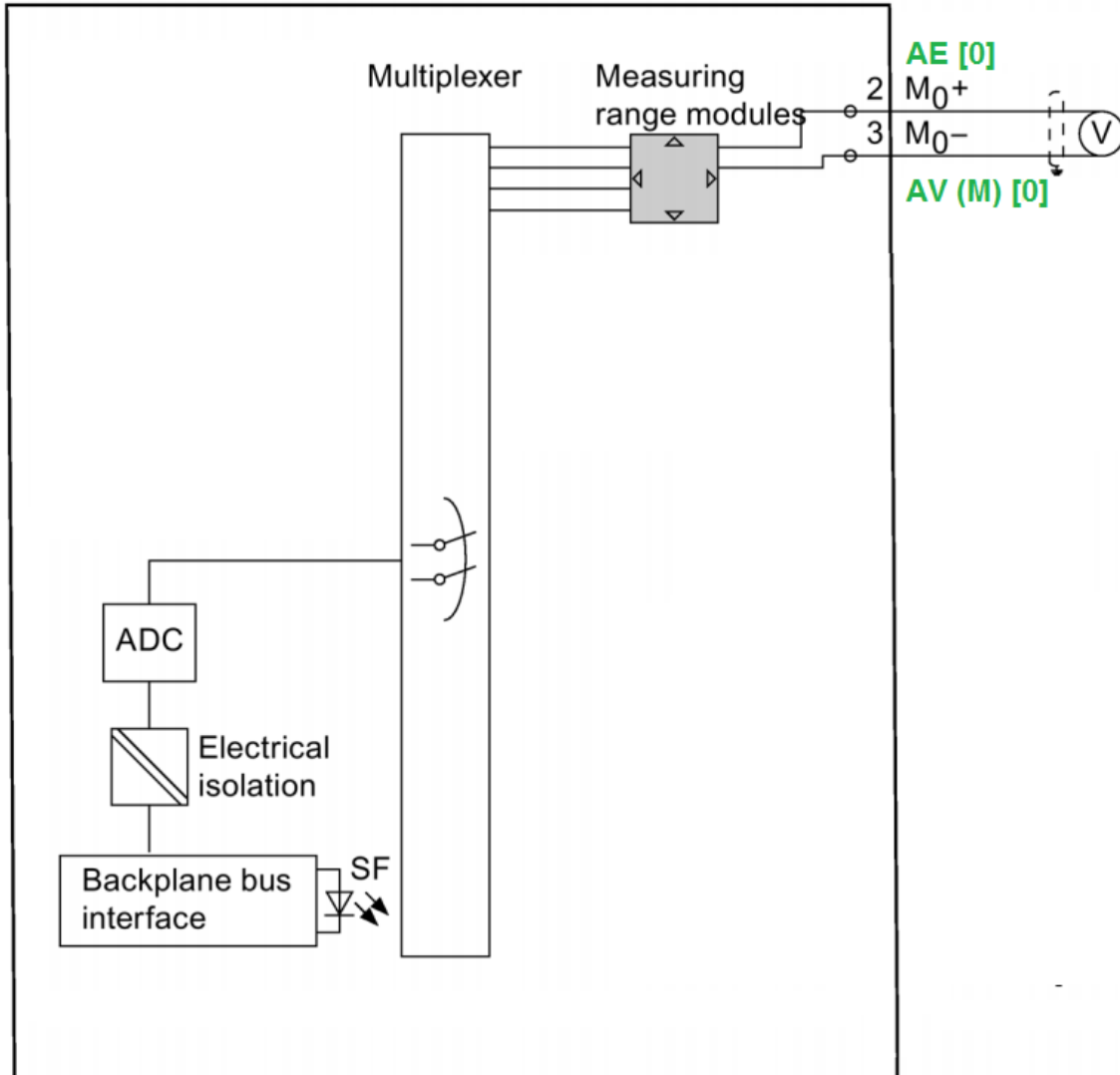

### The complete card

- Now write the function definitions specified for a channel to the further channels, with a different channel designation specification.
- Ensure that you specify the channels in ascending order.
- In addition add the PLC box as function definition at the top position:

Function definition	Connection point designation	Channel designation
PLC box		
PLC connection point, PLC-CS (+)	1	
PLC connection point, AI	2	0
PLC connection point, PLC-PS (M)	3	0
PLC connection point, AI	4	1
PLC connection point, PLC-PS (M)	5	1
PLC connection point, AI	6	2
PLC connection point, PLC-PS (M)	7	2
PLC connection point, AI	8	3
PLC connection point, PLC-PS (M)	9	3
PLC connection point, PLC-CS (M)	10	
PLC connection point, PLC-CS (SH)	11	
PLC connection point, AI	12	4
PLC connection point, PLC-PS (M)	13	4
PLC connection point, AI	14	5
PLC connection point, PLC-PS (M)	15	5
PLC connection point, AI	16	6
PLC connection point, PLC-PS (M)	17	6
PLC connection point, AI	18	7
PLC connection point, PLC-PS (M)	19	7
PLC connection point, PLC-CS (-)	20	



### A different view of the channels

The PLC card used in this example also allows deviating connection wirings thanks to their usage options, and thus deviating channel assignments and other function definition assignments resulting from this:

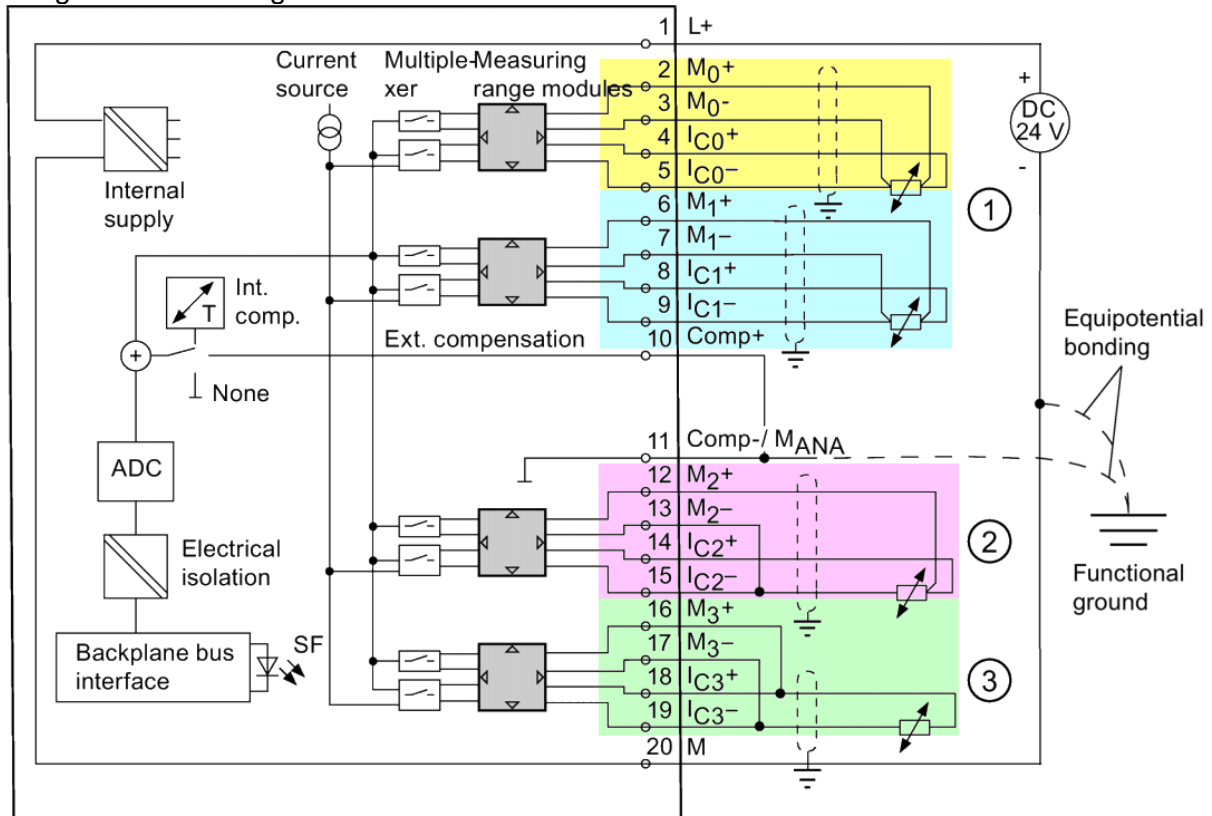

The various channels are have different background colors here and are designated as follows in the example above:

- (1) Two channels with 4-wire circuiting
- (2) One channel with 3-wire circuiting
- (3) One channels with 2-wire circuiting

In this case create a corresponding part variant in the parts management for each circuiting used.

### Network / bus cable

If the module has one or more bus ports to connect extension racks or fieldbus systems, use function definitions from the **Network / bus cable** group for these bus connection points.

You can also find further information on the properties of network connection points in the "**TechTip-PLC-data-exchange**" in the chapter "Automatic connections between network connection points that belong together".

Create a corresponding function template for each bus port (not for each pin of a bus port!). Different function definitions are available to this purpose:

- *General:* Is used for all bus systems.  
For Ethernet-based bus systems enter the designation of the corresponding interface into the **Bus interface: Name** property.
- *Switch connection point:* These connection points are used for passive devices and are treated like busbar connection points. This way all connection points are connected to each other.

In the **Plug designation** field enter the designation of the corresponding pin on the device. The connection point designation remains empty in this case.

For the bus ports the **Plug designation** is identifying together with the **Bus interface: Name** property.

## 2.6.2. Properties in the function templates

<b>Channel designation</b>	<b>20407</b>
(Numerical) value equal to or greater than 0	
<i>The value has to be filled and has to be in accordance with the method of counting and the number system of the PLC configuration program.</i>	

<b>Bus system</b>	<b>20308</b>
Selection list	

<b>Connection point designation</b>	<b>20038</b>
Any string	
<i>The connection point designation has to be unique within a PLC box.</i>	

<b>Connection point description</b>	<b>20039</b>
Any string	
<i>The connection point description has to be unique within a PLC box.</i>	
<i>The connection point description may occur several times at card power supplies.</i>	

<b>Plug designation</b>	<b>20431</b>
Any string	
<i>Value has to be filled at bus ports.</i>	

<b>Bus interface: Name</b>	<b>20447</b>
Any string	
<p><i>Serves to group bus ports for the export of Ethernet-based bus systems. Associated bus ports are combined into a logical unit via this name. To do this use the bus ports of the type "Network / bus cable connection point, general".</i></p> <p><i>Value has to be filled at Ethernet-based bus ports in accordance with the hardware specifications of the PLC manufacturer.</i></p> <p><i>Since Version 2.8 the plug designation is identifying together with the bus interface name.</i></p>	

<b>PLC subdevice: Index</b>	<b>20384</b>
Numerical value in the range of 0 to 12	
<p><i>Specification to which subdevice this PLC connection point belongs.</i></p>	

## 2.7. PLC devices with subdevices

PLC devices that consist of multiple integrated modules can be displayed as multiple devices in the PLC configuration program. This case occurs in particular when the device was made known in the PLC configuration program via a device description file. For the combination of the apparently individual devices as an actual device use the subdevice technology in Eplan.

To do this create the first of these devices with its function templates in the parts management (**Function templates** tab). You also enter the function templates of all other devices under this part and in addition assign the **PLC subdevice: Index** property accordingly to the PLC I/O connection points.

In addition enter the following properties on the **Properties** tab:

- For the main device:
  - **PLC type designation** or
  - **Device description: File name** and **Device description: Index in file**
- For the respective subdevice:
  - **PLC subdevice x: Name**
  - **PLC subdevice x: Position (slot / module)**
  - **PLC subdevice x: PLC type designation** or **PLC subdevice x: Device description: Index in file**

These properties make the identification of the associated devices possible.

As of Eplan version 2022 there is a workflow which supports you with the creation of data for a PLC device with subdevices. Further information is available in the TechTip "**TechTip-Create-PLC-devices-with-subdevices**".

### 3. Macro creation

#### 3.1. Standardized macros

Eplan recommends prepared macros for standardization. In principle macros are not required. But the usage of macros makes the configuration easier. These macros are referenced in the parts.

**Note:**

Please ensure that the functions in the macros match with the function templates in the parts.

- Physical mapping of the rack structure.  
Representation type "single-line", main function

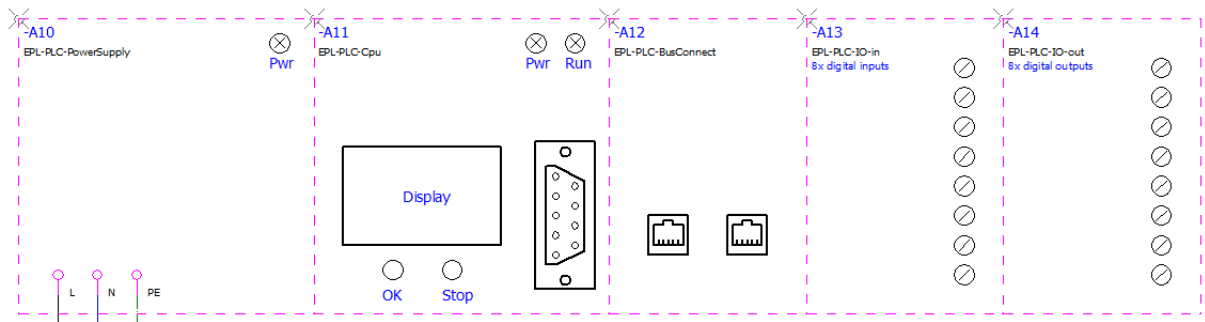

- Overview of complete I/O card as graphical control of the channel assignment.  
Representation type "Overview"
- Channel-wise mapping of the I/O for functionally oriented schematics.  
Representation type "Multi-line"  
(can also be dragged-and-dropped from symbols.)
- Bus ports for mapping the network structure.  
Representation type "Single-line"  
(Separate compact representation or summary with 1.)

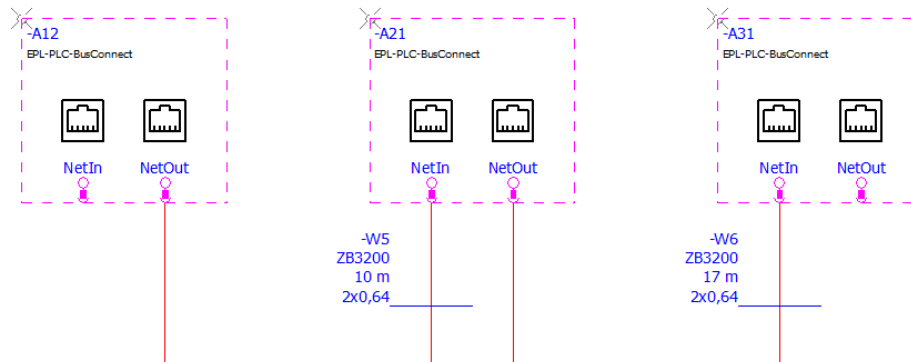

5. Voltage supply (power supply).  
Representation type "Multi-line"  
(Separate compact representation or summary with 1.)

### 3.2. Data in the macro

These data if required are filled with concrete values in the macro and are not changed in the project anymore.

ID	Property	Usage at		
		PLC connection point	Bus port	PLC box
20038	Connection point designation	✓	-	-
20039	Connection point description	✓	-	-
20431	Plug designation	✓	✓	-
20428	Channel designation	✓	-	-
20405	Data type	✓	-	-
20384	PLC subdevice: Index	✓	✓	-
20308	Bus system	-	✓	✓
20312	Subslot	-	✓	✓
20289	Integrated module	-	✓	✓
20409	PLC station: Type	-	-	✓
20416	PLC type designation	-	-	✓
20415	Device description: File name	-	-	✓
20381	Device description: Index in file	-	-	✓
20418	Version	-	-	✓
20432, 20299	Address range (SIEMENS STEP 7 Classic), Address range 2 (SIEMENS STEP 7 Classic)	-	-	✓
20164	Bus coupler / head station	-	-	✓
20189	Bus distribution device	-	-	✓
20184	Power supply	-	-	✓

ID	Property	Usage at		
		PLC connection point	Bus port	PLC box
20167	CPU	-	-	✓
20315	PLC-specific settings	-	-	✓
20444	PLC card is placed on head station	-	-	✓
20447	Bus interface: Name	-	✓	-
20521 foll.	PLC subdevice x: Name	-	-	✓
20533 foll.	PLC subdevice x: Position (slot / module)	-	-	✓
22365, 22341 foll.	PLC subdevice x: PLC type designation	-	-	✓
22366, 22352 foll.	PLC subdevice x: Device description: Index in file	-	-	✓

### 3.3. Graphical view

- All macros for a PLC device are saved in a macro file. This is assigned to the corresponding part.
- The functions used for the graphical view must correspond with the function templates defined in the part.
- The PLC macros contain:
  - PLC connection points
  - PLC boxes
  - Graphic.

#### Single-line (PLC box)

- The macro is used for the representation of the rack structure.
- The **Main function** check box is to be activated at the PLC box.

- The macro consists of a PLC box and can contain graphic elements and / or images, see example:

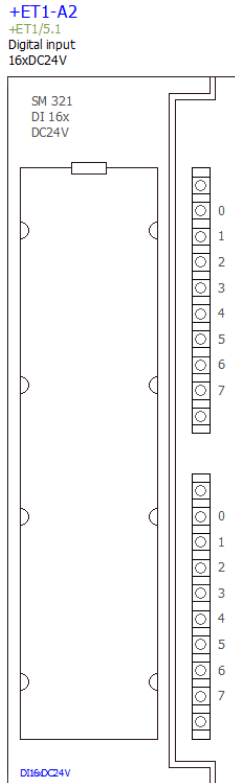

- Connection points are not represented.

## Overview

- An overview macro can look as follows:





- The special symbol "40" (PLCCPOV) with the following data is used for these connection points:
  - Property arrangement "Default value horizontal"
  - Move the "All connection point descriptions" property to the inside (X=0; Y=1,3)
- The following applies for bus ports:
  - Same DT, plug designation and function definition as in the single-line representation.
  - The following indirect properties are to be used for the properties to be displayed.
- The inside of the box can be designed freely.
- Connection points should be arranged in such a way that they correspond to the real device in order to have a recognition value.
- The overview macro is saved as "Variant A" in the "Overview" representation type.

### Mounting panel (2D panel layout)

- Devices have to be drawn true to scale.
- The function definition "Part placement, PLC card" must be used.